

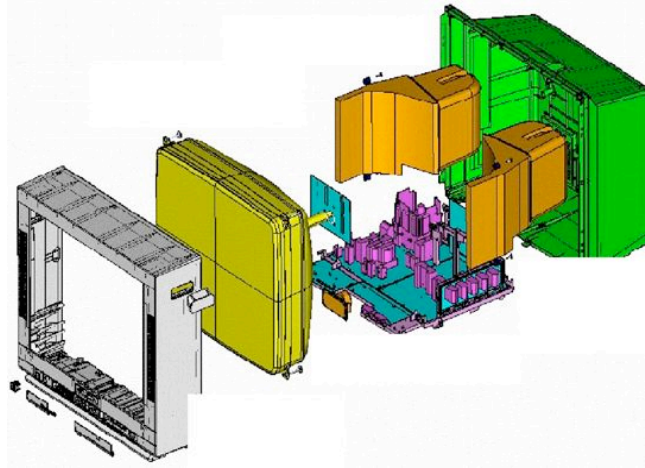

## *CRT Glass Trading*



*Building a bridge  
Product to Product*

## Who are we? EcologyNet Europe – The Company

Based in Wiesbaden, the company is still young (establishment in April 2005), but our experts have been involved in WEEE disposal and recycling issues since May 2002.

In the global competition of such systems, Japan established recycling of end-of-life equipment as far back as 2001. The company put in charge of this task was our sister company EcologyNet Japan. The company runs one of two parallel existing systems and commissions, administers and controls all necessary steps for 21 well known producers.

ENE EcologyNet GmbH is a subsidiary of Panasonic. This means that both the quality requirements and the high ecological standards of our parent company apply to us.

### What do we do?

EcologyNet has strong connections to interested buyers of cleaned CRT glass who are looking to ensure a constant material flow for the production of consumer electronics products. The high quality of such material flow can only be reached by an advanced technology.

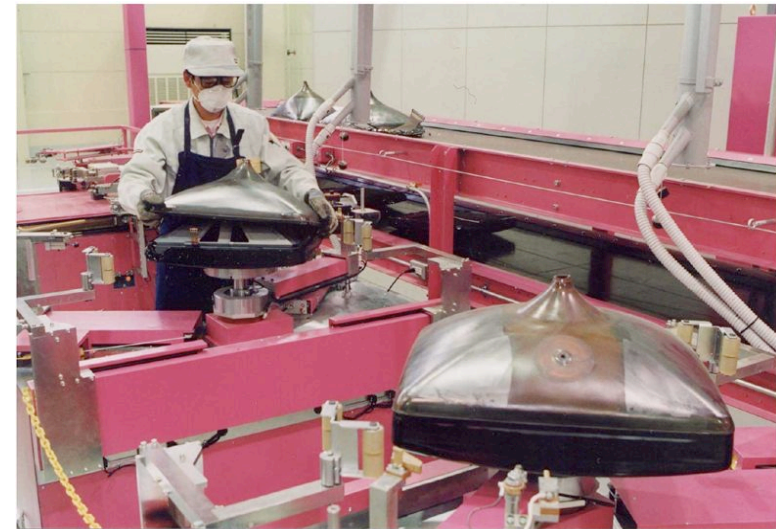

Our knowledge and powerful consultation embraces all project phases:

- We offer comprehensive technical support, incl. the necessary machinery to work with
- We have strong contacts to producers of CRT sets, asking for a constant flow of cleaned glass according to a strong material specification
- We support you in the process of achieving the desired glass specification

## Who are we looking for?

Choosing a recycling partner is a matter of trust. You will only have the necessary security once you are convinced of a partner's competence and reliability.

We are looking for you if you are able to deliver high quality cleaned CRT glass, on a constant flow, achieving the high expectations raised by our partners, the CRT manufacturers.

Currently we need strategic partners in France, the Netherlands, Belgium, Poland, Austria and Switzerland. For the remaining European countries, we look for suppliers of our strategic partners. Our minimum requirement are 220.000 TV sets or 3.000 tons glass p.a.

The table shows you some different alternatives you have to deal with glass. By achieving a high quality processing of glass, the best choice should be to contact us!

Process	Cost / Revenue	Result
Internal cleaning of CRT	- CRT removing - internal cleaning	-
Separated CRT (panel & funnel)	- P/F separation + sales	+
Cleaned CRT (panel & funnel)	- P/F cleaning +sales	++

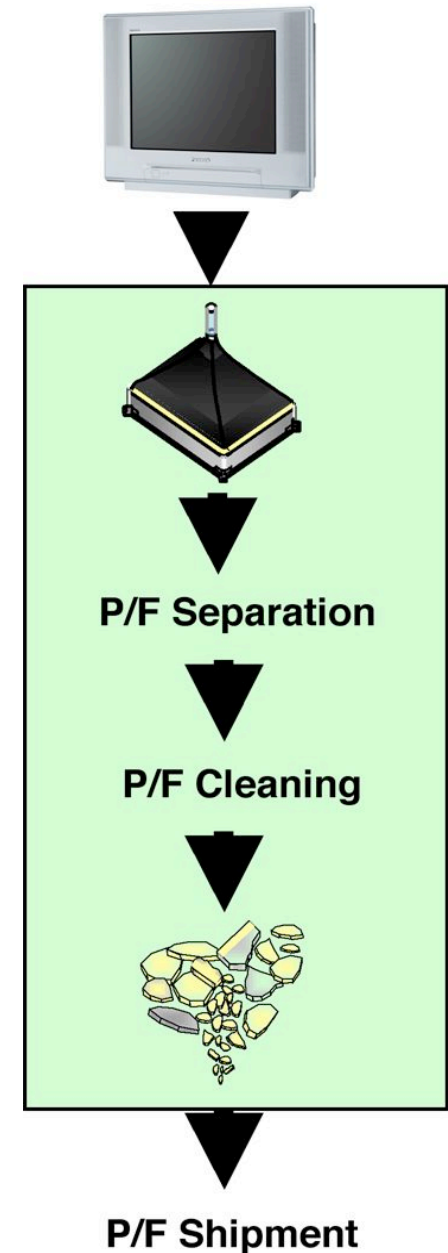

Please contact us for further details:

**ENE EcologyNet Europe GmbH**

Hagenauer Strasse 43

D-65203 Wiesbaden

Tel. : +49 (0) 611 235 375

Fax : +49 (0) 611 235 195

Email: [Info@ecologynet-eu.com](mailto:Info@ecologynet-eu.com)

[Http://www.ecologynet-europe.com](http://www.ecologynet-europe.com)

